

The 2.4 mm LCP™ Distal Radius System. A comprehensive plating system to address a variety of fracture patterns.

Technique Guide



Table of Contents

Introduction

The 2.4 mm LCP Distal Radius System	2
– Dorsal Distal Radius Plates	
– Volar Distal Radius Plates	
– Extra-articular Volar Distal Radius Plates	
<hr/>	
AO ASIF Principles of Internal Fixation	4
<hr/>	
Indications	5
<hr/>	
Clinical Cases	6

Surgical Technique

General Technique	12
<hr/>	
Dorsal Surgical Technique	17
<hr/>	
Volar Plating with Extra-articular Plates	21
<hr/>	
Volar Plating with Juxta-articular Plates	24
<hr/>	
Volar Plating for Dorsally-Displaced (Colles') Fractures	26
<hr/>	
Postoperative Treatment	28
<hr/>	
Implant Removal	28

Product Information

Screws	29
<hr/>	
Plates	30
<hr/>	
Instruments	33
<hr/>	
Set List	36
<hr/>	
Sterilization Parameters	36
<hr/>	
References	41

The 2.4 mm LCP Distal Radius System

- Smaller plates and screws address fracture fragments individually, with less overall implant bulk
- Different dorsal and volar plates allow implant placement to match the individual fracture pattern
- Two volar plate designs offer the choice of extra-articular placement for simpler fixation, or juxta-articular placement for more complex fractures
- Low plate-and-screw profile minimizes potential for tendon and soft tissue irritation
- Rounded edges minimize potential for tendon adhesion
- Locking screws offer a fixed-angle construct to support the articular surface, reduce the need for bone graft, and obtain fixation in osteoporotic bone

- Choice of two lengths of each type of plate precludes the need to cut plates which can result in tendon irritation
- Available in stainless steel and titanium
- Locking Compression Plates (LCP) have Combi holes which allow locking screw fixation in the threaded section, or compression in the nonthreaded section of the hole



Undercuts

Undercuts on the bottom of the plates facilitate fine contouring and ensure a smooth top surface; straight plates and four-hole-head extra-articular plates do not have undercuts.

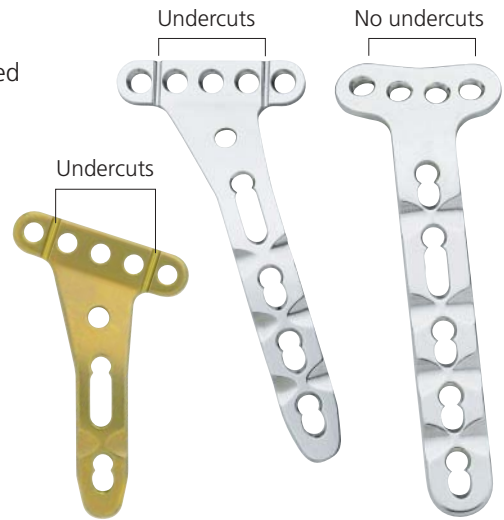

Dorsal Plates

The two-plate technique of dorsal fixation of distal radius fractures offers increased stabilization. This is due to the 70°–90° angle between the two plates. One plate buttresses the radial column (the dorsoradial plate), and the other plate supports the intermediate column (the dorsoulnar plate).

Right-angle L-plates, oblique L-plates, T-plates and straight plates are used in the dorsal two-plate technique. This offers a strong construct for complex distal radius fractures, avoids removal of Lister's tubercle and decreases tendon and soft tissue irritation.

Straight plates, precontoured to fit the radial column, have a notched tip that allows these plates to fit on the radial styloid adjacent to a temporary K-wire fixation.



Straight distal radius plate, end detail



Volar plates

Volar plates are precontoured for anatomical fit. The complex AP bend fits the volar surface of the distal radius. Proximal 5° angulation of threaded holes allows more distal placement of the plate.



A volar approach is usually used for volarly displaced fractures, and may be preferable for some dorsally displaced fractures.

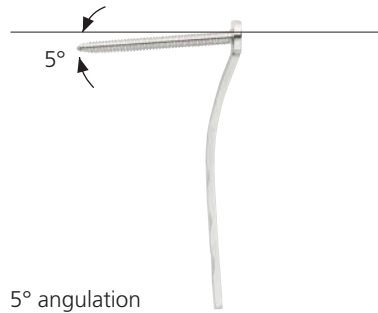

Extra-articular volar plates

Plate is positioned away from articular surface.

Diverging screws secure styloid and distal fragments.

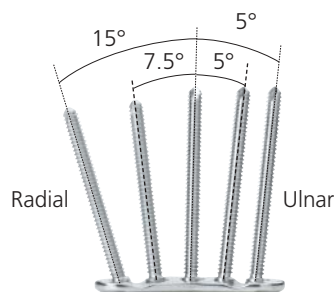
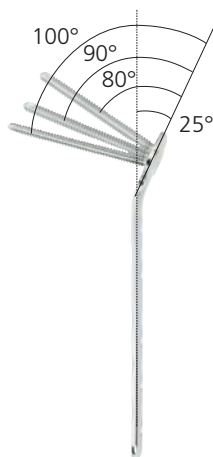

AO ASIF Principles of Internal Fixation

In 1958, the AO ASIF (Association for the Study of Internal Fixation) formulated four basic principles which have become the guidelines for internal fixation.¹ Those principles, as applied to the 2.4 mm LCP Distal Radius Plates, are:

Anatomic Reduction

Facilitates restoration of the articular surface with locking screws. Multiple volar and dorsal plates provide fixation options for a variety of fracture patterns.

Stable Fixation

Locking screws create a fixed-angle construct, providing angular stability.

Preservation of Blood Supply

Locked plates do not need close contact with the bone, limiting vascular trauma.

Early, Active Mobilization

Early mobilization per standard AO technique creates an environment for bone healing, expediting a return to optimal function.

1. M. E. Müller, M. Allgöwer, R. Schneider, and H. Willenegger. *AO Manual of Internal Fixation*, 3rd Edition. Berlin: Springer-Verlag. 1991.

Indications

For fixation of complex intra- and extra-articular fractures and osteotomies of the distal radius and other small bones.



Three-column theory of dorsal distal radius fracture fixation

■ Radial column

Lateral side of radius including the radial styloid and scaphoid fossa

■ Intermediate column

Ulnar side of radius, including the lunate fossa and sigmoid notch

■ Ulnar column

Ulnar head, including the triangular fibrocartilage complex (TFCC) and the ulnar part of distal radioulnar joint (DRUJ)



Columns of the distal radius

Clinical Cases—Dorsal Approach

Case 1

A 24-year-old male who fell at work from a height of 2.5 meters (about 8 feet). Intra-articular fracture with fragments into metaphysis. The fracture could not be reduced by closed means.

Case 2

Comminuted intra-articular fracture; radiocarpal joint reconstruction using dorsal approach.



Preoperative lateral view



Preoperative AP view



Postoperative

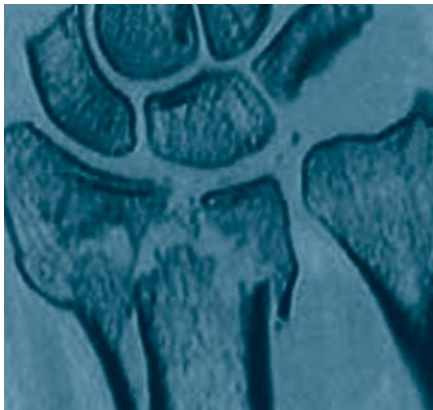

Preoperative



Preoperative lateral view



Preoperative AP view



Postoperative



Clinical Cases—Volar Approach

Case 1

Comminuted intra-articular fracture; radiocarpal joint reconstruction using volar approach.

Case 2

A 34-year-old woman with reverse Barton fracture.

Case 3

A 58-year-old woman with a volar comminuted fracture, with full return of motion and function.

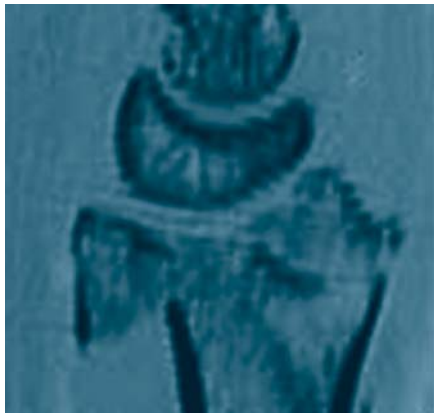

Preoperative



Preoperative lateral view



Preoperative AP view



Postoperative lateral view



Postoperative AP view



Preoperative lateral view



Preoperative AP view



Postoperative lateral view



Postoperative AP view



Preoperative lateral view



Preoperative AP view



Postoperative lateral view



Postoperative AP view

Clinical Cases—Volar Approach—Extra-articular Plates

Case 1

Comminuted, dorsally-displaced fracture of the distal radius; fixation with a five-hole head extra-articular plate.

Case 2

Comminuted, dorsally-displaced fracture of the distal radius; fixation with a four-hole head extra-articular plate.

Case 3

A 50-year-old male who fell from a height of 6 feet. Highly comminuted fracture with 50% dorsal displacement and 20° of dorsal tilt.



Preoperative lateral view



Preoperative AP view



Preoperative lateral view



Preoperative AP view



Preoperative lateral view



Preoperative AP view



Postoperative lateral view



Postoperative AP view



Preoperative lateral view



Preoperative AP view



Postoperative lateral view



Postoperative AP view

General Technique

1

Plate contouring

Instruments

323.029 Threaded LCP Drill Guide

329.12 Bending Pliers

329.922 Bending Pins

Contour plates as needed using Bending Pliers.

If necessary, fine bending of the distal tabs may be achieved using Bending Pins or Threaded LCP Drill Guides. Be careful to avoid overbending and damage to plate threads.

Note: The plate holes have been designed to accept some degree of deformation. Undercuts help protect the threaded holes from distortion. Significant distortion of the locking holes reduces locking effectiveness.



329.12

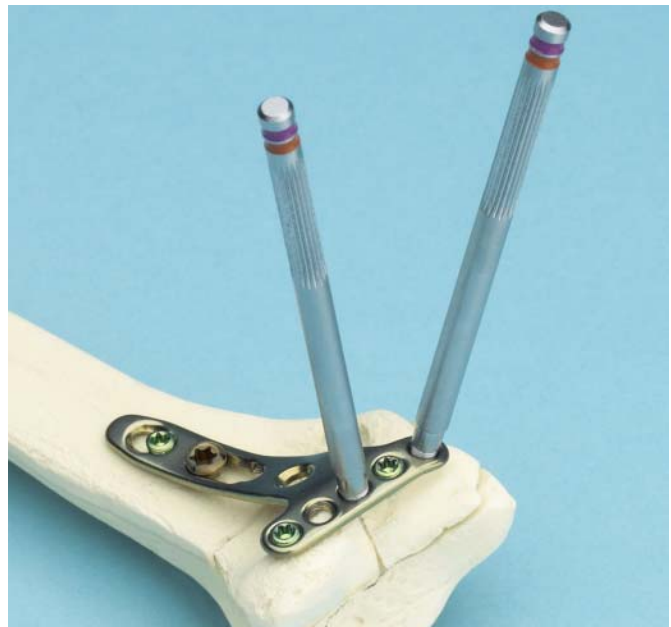

2

Temporary fixation with K-wires

Instruments

323.029	Threaded LCP Drill Guide
324.084	1.25 mm K-Wire Insert

K-wires may be placed through the Threaded LCP Drill Guide using the 1.25 mm K-Wire Insert. Thread the drill guide into a locking hole and place the K-wire insert into the drill guide. Insert the K-wire.

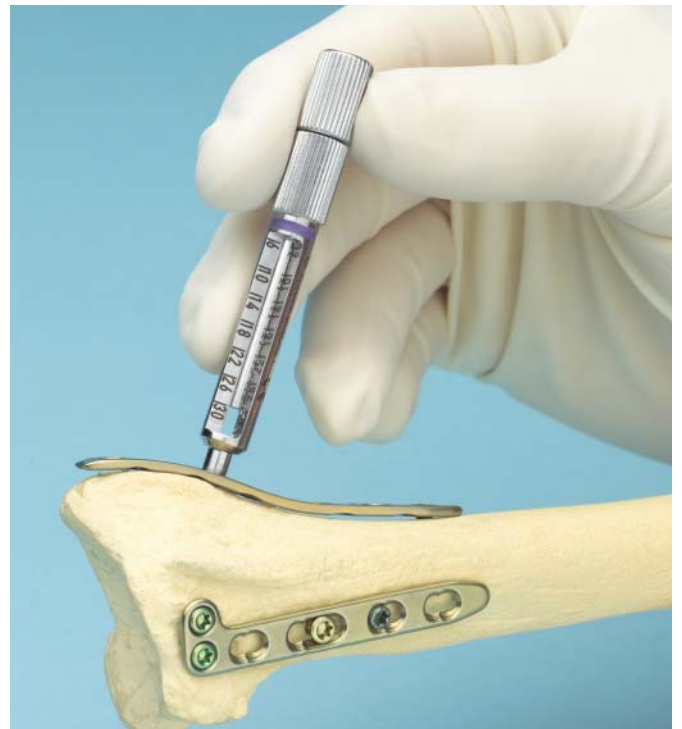

3

Screw insertion

Determine where locking screws will be used. Use 2.4 mm locking screws in the distal portion of the plate and 2.4 mm locking or 2.4 mm cortex screws in the shaft of dorsal and volar plates.

2.7 mm cortex screws can be used only in the Combi holes in the shaft of the volar plates.

If a combination of locking and cortex screws is planned, a cortex screw should be used first to pull the plate to the bone.

If a locking screw is used first, care should be taken to ensure that the plate is held securely to the bone to avoid spinning of the plate as the screw is locked into the plate.

4

Insert cortex screws

Instruments

310.19	2.0 mm Drill Bit
310.26	2.7 mm Drill Bit
310.509	1.8 mm Drill Bit
310.530	2.4 mm Drill Bit
311.43	Handle, with quick coupling
314.467	StarDrive Screwdriver Shaft, T8
319.006	Depth Gauge
322.202	2.4 mm Universal Drill Guide
322.26	2.7 mm Universal Drill Guide

Use the 2.4 mm Universal Drill Guide or the 2.7 mm Universal Drill Guide for an eccentric (compression) or neutral (buttress) insertion of cortex screws.

For the 2.4 mm cortex screw, use the 1.8 mm drill bit for the threaded hole and the 2.4 mm drill bit for the gliding hole.

For 2.7 mm cortex screws, use the 2.0 mm drill bit for the threaded hole and the 2.7 mm drill bit for the gliding hole.

5

Insert locking screws

Instruments

310.509	1.8 mm Drill Bit with depth mark
311.43	Handle, with quick coupling
314.467	StarDrive Screwdriver Shaft, T8
319.006	Depth Gauge
323.029	Threaded LCP Drill Guide

Screw the Threaded LCP Drill Guide into a hole until it is fully seated.

Use the 1.8 mm Drill Bit with depth mark to drill to the desired depth. Determine the screw length directly from the mark on the drill bit and scale on the threaded drill guide. This may also be checked using a Depth Gauge.

Insert the locking screw manually with the self-retaining StarDrive Screwdriver Shaft and Handle. Carefully tighten the locking screw. Excessive force is not necessary to lock the screw to the plate.



Determine desired screw length using mark on drill bit.



Lock the screw into the plate.

5

Insert locking screws continued

Alternative technique

Instruments

311.43	Handle, with quick coupling
--------	-----------------------------

314.467	StarDrive Screwdriver Shaft, T8
---------	---------------------------------

314.468	Holding Sleeve
---------	----------------

An alternate method may be used for insertion of locking screws, using the locking screw to pull the plate to the bone. Place the Holding Sleeve onto the StarDrive Screwdriver Shaft. Pick up the locking screw with the holding sleeve, and insert the screw into the screw hole (A). With the locking screw still held by the holding sleeve, tighten the screw until the plate is drawn to the bone (B, C). Pull up on the holding sleeve to release the screw head, and tighten the locking screw into the plate (D).



Dorsal Surgical Technique

1

Patient position

- 1 Place the patient in the supine position with the hand and arm on a hand table, preferably radiolucent for fluoroscopic imaging.

2

Approach

Make a straight incision 5 cm to 9 cm in length, approximately 2 cm proximally from the base of the second metacarpal over Lister's tubercle to the border of the muscle belly of the first extensor compartment.

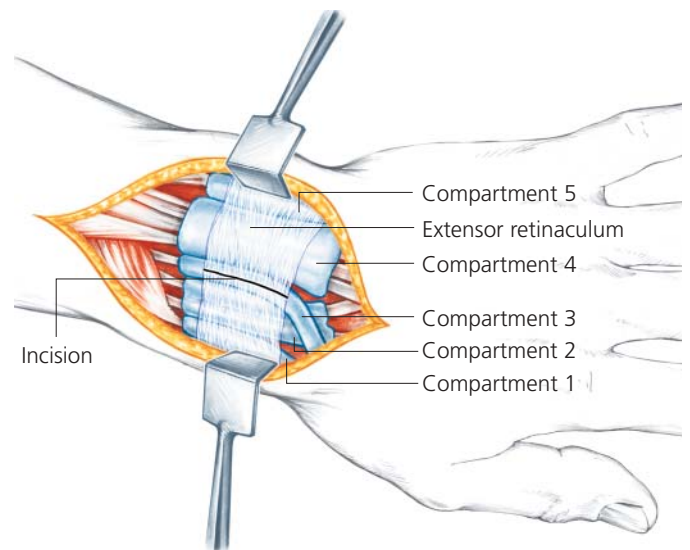

3

Open the extensor retinaculum

Open the extensor retinaculum using a longitudinal incision over the third compartment. Dissect the extensor pollicis longus (EPL) tendon and place it in a vessel loop for manipulation.

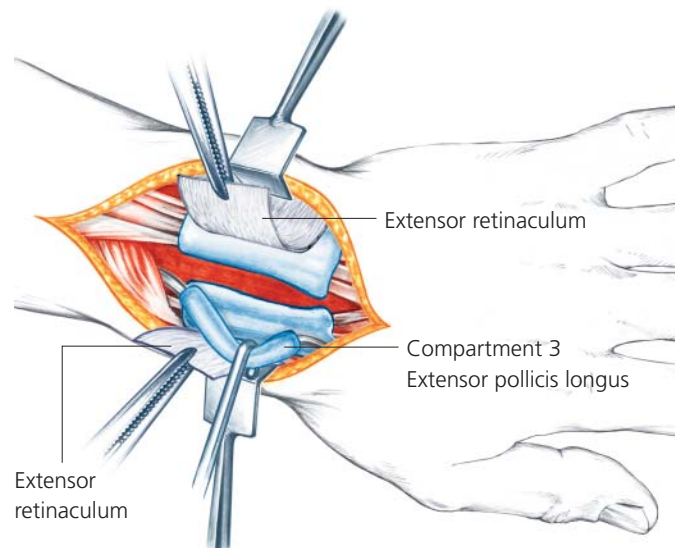

4

Continue to dissect

Elevate the second and fourth dorsal compartments subperiosteally to preserve the integrity of these compartments so there will be no direct contact between the tendons and implants. On the ulnar side, continue to dissect toward the radial border of the DRUJ, preserving the ligament and joint capsule. On the radial side, dissect toward the brachioradialis tendon to place the dorsoradial plate correctly to support the radial styloid.

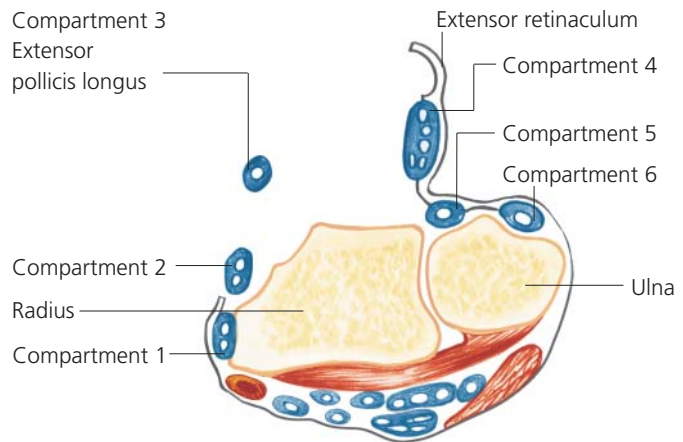

Cross-sectional view

5

Reduce the fracture and apply dorsoulnar plate

Instruments

310.509	1.8 mm Drill Bit
311.43	Handle, with quick coupling
314.467	StarDrive Screwdriver Shaft, T8
323.202	2.4 mm Universal Drill Guide

Reduce the fracture. Begin fixation on the intermediate column with the dorsoulnar plate, adapting it carefully to the surface of the bone. This plate supports the intermediate column and fixes the dorsoulnar fragment. Fix the plate preliminarily with a 2.4 mm cortex screw in the shaft fragment close to the fracture (buttress position). Use the 1.8 mm Drill Bit for 2.4 mm cortex screw.

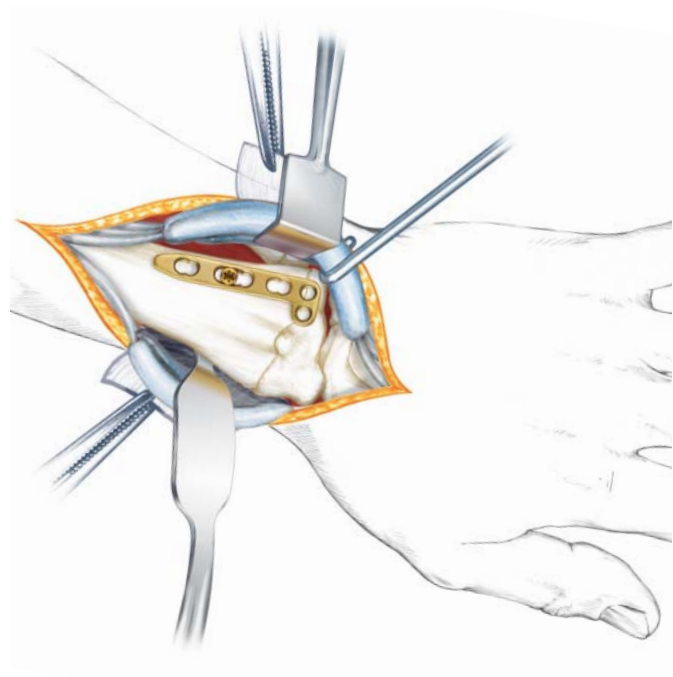

6

Position the dorsoradial plate

- For the radial column, position the dorsoradial plate beneath the first compartment to support the radial styloid. Fix it to the bone with a 2.4 mm cortex screw in the shaft close to the fracture. It should form an angle of approximately 70° – 90° to the dorsoulnar plate. Confirm correct reduction and position of the plates with fluoroscopy.



Alternative technique

The dorsoradial plate may be placed using a separate incision between the first and second extensor compartments. Use caution with the alternative approach to protect branches of the superficial radial nerve in the skin flap.

The dorsoulnar plate may be placed through a separate incision into the fifth extensor compartment. The extensor retinaculum over the distal part of the third compartment may be preserved so that the tendon is guided along its course toward the thumb. For additional information on technique alternatives, see D. Rikli and P. Regazzoni, "The double plating technique for distal radius fractures," *Techniques in Hand and Upper Extremity Surgery*, 2000, 4(2), 107–114.

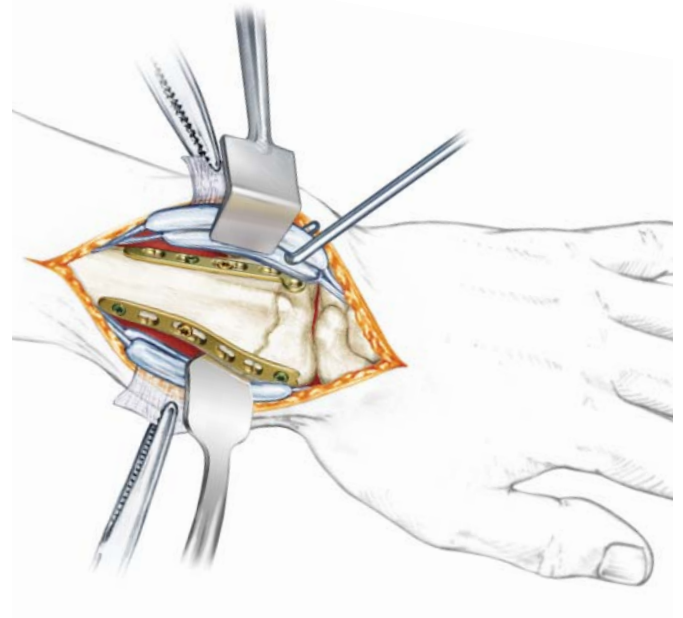

7

Complete the fixation

Complete the fixation. Using two screws in the distal fragment and two screws in the proximal fragment will usually provide sufficient stability.



8

Create a flap

Create a flap with the extensor retinaculum by pulling it underneath the EPL and suturing it. The extensor retinaculum lies between the EPL and the dorsoulnar plate to avoid direct contact with the structures.

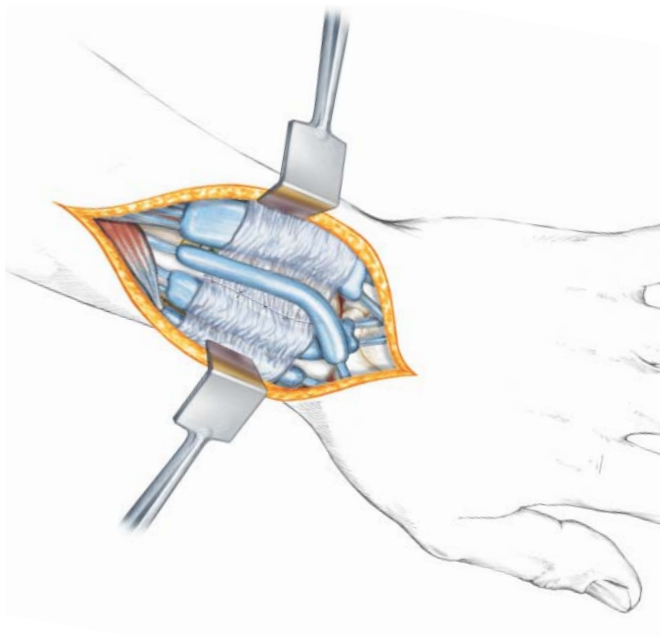

9

Close the incision

Use the appropriate method for surgical closure of the incision.

Volar Plating with Extra-articular Plates

Extra-articular plates may be used more often with simple fractures (AO Types A, some B and C1). Placement of extra-articular plates is farther away from the articular surface.

1

Approach

Make a longitudinal incision slightly radial to the flexor carpi radialis tendon (FCR). Dissect between the FCR and the radial artery, exposing the pronator quadratus. Detach the pronator quadratus from the lateral border of the radius and elevate it toward the ulna.

Important: Leave the volar wrist capsule intact to avoid devascularization of the fracture fragments and destabilization of the volar wrist ligaments.

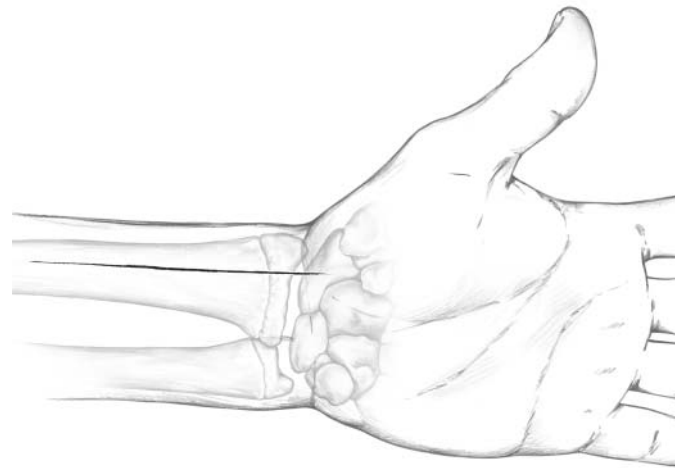

2

Reduce fracture

Instruments

310.19	2.0 mm Drill Bit
310.509	1.8 mm Drill Bit
311.43	Handle, with quick coupling
314.467	StarDrive Screwdriver Shaft, T8
323.202	2.4 mm Universal Drill Guide
323.26	2.7 mm Universal Drill Guide

To reduce the fracture, apply the plate to fit the extra-articular volar surface and insert a 2.4 mm or 2.7 mm cortex screw into the long hole in the shaft. Adjust the plate position as necessary, and tighten the screw.



The order of screw insertion in the shaft and metaphysis may vary depending on fracture pattern and reduction technique. Verify plate and distal screw location with drill bit or K-wires before inserting multiple screws.

3

Insert proximal screws

Determine where 2.4 mm locking or 2.4 mm or 2.7 mm cortex screws will be used in the shaft of the volar plate. Insert these screws beginning with the most proximal screw.



4

Insert distal screws

Instruments

310.509	1.8 mm Drill Bit
311.43	Handle, with quick coupling
314.467	StarDrive Screwdriver Shaft, T8
323.029	Threaded LCP Drill Guides
329.922	Bending Pins

Insert 2.4 mm locking screws into the distal part of the plate. If necessary, for the five-hole-head plate, fine bending of the tabs at the outer ends of the distal portion of the plate may be achieved using Threaded Drill Guides or Threaded Bending Pins. Be careful to avoid overbending and damage to screw hole threads.



5

Confirm proper joint reconstruction

- Confirm proper joint reconstruction, screw placement and screw length using multiple C-arm views. To assure that the most distal screws are not in the joint, use additional views, such as 10° tilted AP, 20° inclined lateral, and 45° pronated oblique.



Straight AP



10° dorsal tilt



Lateral



20° radial tilt

6

Close incision

Use the appropriate method for surgical closure of the incision.

Volar Plating with Juxta-articular Plates

Juxta-articular plates may be used more often with complex fractures (AO Types C2 and C3). Placement of juxta-articular plates is as distal as possible on the radius.

1

Approach and fracture reduction

Make a longitudinal incision slightly radial to the flexor carpi radialis tendon (FCR). Dissect between the FCR and the radial artery, exposing the pronator quadratus. Detach the pronator quadratus from the lateral border of the radius and elevate it toward the ulna. Reduce the fracture.

2

Contour the plate

Instruments

323.029 Threaded LCP Drill Guide

329.922 Bending Pin

Contour the plate carefully for position as distal as possible. If necessary, fine bending of the distal tabs may be achieved using Bending Pins or Threaded LCP Drill Guides. Be careful to avoid overbending and damage to plate threads.



3

Determine placement and insert proximal screws

Instruments

310.19	2.0 mm Drill Bit
310.509	1.8 mm Drill Bit
311.43	Handle, with quick coupling
314.467	StarDrive Screwdriver Shaft, T8
323.202	2.4 mm Universal Drill Guide
323.26	2.7 mm Universal Drill Guide

After reducing the fracture, apply the plate and insert a 2.4 mm or 2.7 mm cortex screw into the long hole in the shaft. Adjust the plate position as necessary, and tighten the screw. Determine where locking or cortex screws will be used in the shaft of the volar plate. Insert these screws beginning with the most proximal screw.



4

Insert distal screws

Instruments

311.43	Handle, with quick coupling
314.467	StarDrive Screwdriver Shaft, T8
314.509	1.8 mm Drill Bit with depth mark
323.029	Threaded LCP Drill Guide

Insert 2.4 mm locking screws into the distal part of the plate.



5

Close incision

Use the appropriate method for surgical closure of the incision.

Volar Plating for Dorsally–Displaced (Colles’) Fractures

These fractures may be fixed with either extra-articular or juxta-articular plates.

1

Apply the plate

Instruments

310.509	1.8 mm Drill Bit with depth mark
311.43	Handle, with quick coupling
314.467	StarDrive Screwdriver Shaft, T8
323.029	Threaded LCP Drill Guide

Apply the plate very distally using the technique described above. Screw the Threaded LCP Drill Guide into the middle distal plate hole and drill to the desired depth with the 1.8 mm Drill Bit with depth mark at an angle of 10°–15° from the articular surface.

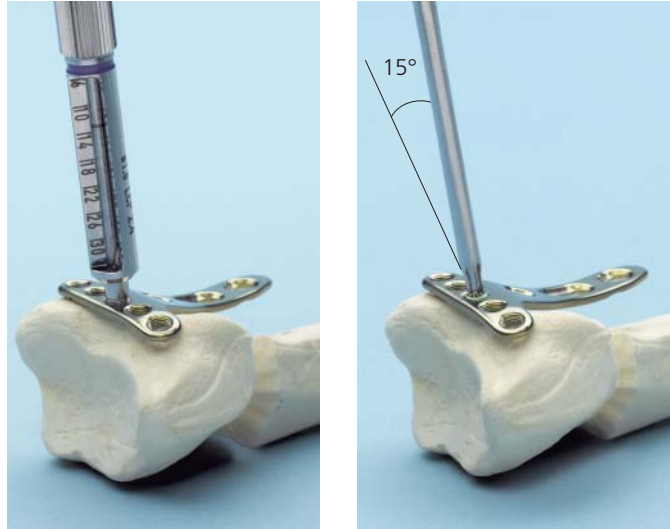

2

Insert locking screws

Insert 2.4 mm locking screws as needed in the distal end of the plate.



3

Reduce the fracture

Reduce the fracture by positioning the plate onto the shaft.



4

Insert locking or nonlocking screws

Insert at least two screws, either locking (2.4 mm) or nonlocking (2.4 mm or 2.7 mm), into the shaft.



5

Close incision

Use the appropriate method for surgical closure of the incision.

Postoperative Treatment and Implant Removal

Postoperative treatment

Postoperative treatment with locking compression plates does not differ from conventional internal fixation procedures.

Implant removal

To remove locking screws, unlock all screws from the plate and then begin to remove the screws completely from the bone. This avoids rotation of the plate when removing the last locking screw.

Screws Used with the 2.4 mm LCP Distal Radius Plates

Stainless Steel and Titanium

2.4 mm Locking Screws, self-tapping, with StarDrive recess

- Threaded, conical head locks securely into the threaded holes in the plate to provide angular stability
- Locked screws allow unicortical screw fixation and load transfer to the near cortex
- 6 mm to 30 mm lengths (2 mm increments)
- Self-tapping tip



Note: For information on fixation principles using conventional and locked plating techniques, please refer to the *Small Fragment Locking Compression Plate (LCP) System Technique Guide*.

2.4 mm Cortex Screws, self-tapping, with StarDrive recess

- For use in round or Combi holes
- Low-profile head in the plate holes
- Used to provide compression or neutral fixation
- 6 mm to 30 mm lengths (2 mm increments)



2.7 mm Cortex Screws, self-tapping, with StarDrive recess

- For use in Combi holes of the 2.4 mm LCP volar distal radius plates
- Used to provide compression or neutral fixation
- 10 mm to 30 mm lengths (2 mm increments)



Note: The T8 StarDrive recess in the screw head offers improved torque transfer, high strength, and self-retention of screws, when compared to cruciform and hexagonal drives. Please note the StarDrive recess in the surgical report. This will remind the surgeon to have a StarDrive screwdriver available for removing these screws.

Stainless steel screws are made of implant quality 316L stainless steel
Titanium screws are made of titanium alloy, Ti-6Al-7Nb

Dorsal Distal Radius Plates

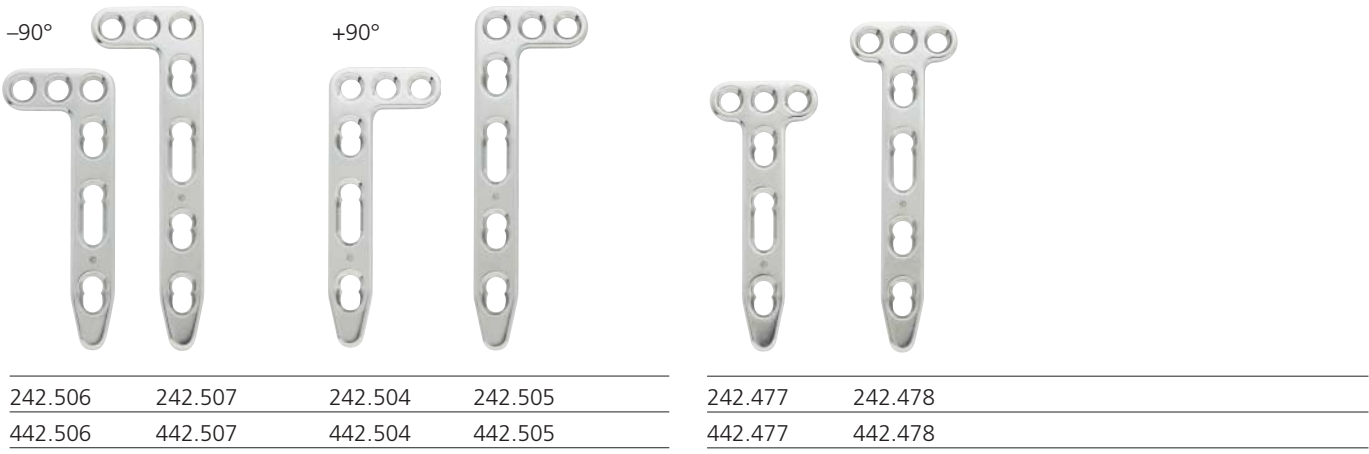
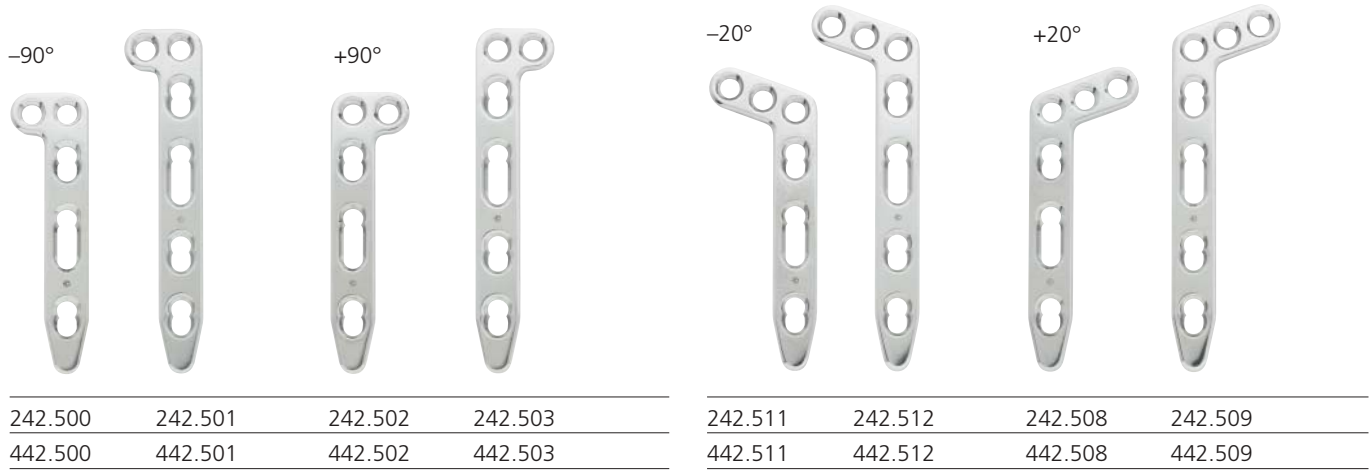

Note: Product numbers beginning with "2" are stainless steel plates.
Product numbers beginning with "4" are titanium or titanium alloy plates.

Volar Distal Radius Plates

Left



242.491	242.492
442.491	442.492

Right



242.493	242.494
442.493	442.494

Note: Product numbers beginning with "2" are stainless steel plates.
 Product numbers beginning with "4" are titanium or titanium alloy plates.

Extra-articular Volar Distal Radius Plates

Left



242.461	242.467
442.461TM	442.467TM

Right



242.458	242.464
442.458TM	442.464TM

Left



242.462	242.468
442.462TM	442.468TM

Right



242.459	242.465
442.459TM	442.465TM

Note: Product numbers beginning with "2" are stainless steel plates.
Product numbers beginning with "4" are titanium or titanium alloy plates.

Instruments

310.19 2.0 mm Drill Bit, quick coupling



310.26 2.7 mm Drill Bit, quick coupling



310.509 1.8 mm Drill Bit with depth mark, quick coupling



310.530 2.4 mm Drill Bit, quick coupling



311.43 Handle, with quick coupling



314.467 StarDrive Screwdriver Shaft, T8



314.468 Holding Sleeve, for 314.467



319.006 Depth Gauge, for 2.0 mm and 2.4 mm screws



319.01 Depth Gauge, for 2.7 mm screws



319.39 Sharp Hook



323.029 Threaded LCP Drill Guide, 1.8 mm



323.202 2.4 mm Universal Drill Guide



323.26 2.7 mm Universal Drill Guide



324.084 1.25 mm K-Wire Insert, for 323.029



329.12 Bending Pliers



329.922 Bending Pin, for 2.4 mm Locking Plates



398.41 Reduction Forceps with Points, broad



398.95 Termite Forceps



399.18 Hohmann Retractor, small



399.48 Periosteal Elevator, 3 mm width, curved blade, straight edge



399.481 Periosteal Elevator, 3 mm, curved blade, round edge



399.97 Reduction Forceps, with points



2.4 mm LCP Distal Radius Plate Instrument and Implant Sets

Stainless Steel (105.515) and Titanium (145.515)

Graphic Cases

- 306.450 Graphic Case, for LCP Distal Radius Plate Set
 690.384 Graphic Case, for Titanium LCP Distal Radius Plate Set

Instruments

- 310.19 2.0 mm Drill Bit, quick coupling, 100 mm, 2 ea.
 310.26 2.7 mm Drill Bit, quick coupling, 100 mm, 2 ea.
 310.509 1.8 mm Drill Bit with depth mark, quick coupling, 110 mm, 2 ea.
 310.530 2.4 mm Drill Bit, quick coupling, 100 mm, 2 ea.
 311.43 Handle, with quick coupling
 314.467 StarDrive Screwdriver Shaft, T8, 105 mm, 2 ea.
 314.468 Holding Sleeve, for 314.467
 319.006 Depth Gauge, for 2.0 mm and 2.4 mm screws
 319.01 Depth Gauge, for 2.7 mm screws
 319.39 Sharp Hook
 323.029 Threaded LCP Drill Guide, 1.8 mm, 2 ea.
 323.202 2.4 mm Universal Drill Guide
 323.26 2.7 mm Universal Drill Guide
 324.084 1.25 mm K-Wire Insert, for 323.029
 329.12 Bending Pliers, 2 ea.
 329.922 Bending Pin, for 2.4 mm Locking Plates, 2 ea.
 398.41 Reduction Forceps with Points, broad
 398.95 Termite Forceps, 90 mm
 399.18 Hohmann Retractor, small, 6 mm width
 399.48 Periosteal Elevator, 3 mm width, curved blade, straight edge
 399.481 Periosteal Elevator, 3 mm, curved blade, round edge
 399.97 Reduction Forceps, with points



Sterilization Parameters for Sets (105.515 and 145.515)

These Synthes sets with all additionally available items, as marked in the cases or modules, can be sterilized by the following parameters. For more information, please see graphic case package insert.

Method	Cycle	Temperature	Exposure Time
Steam	Prevacuum (Wrapped)	132°–135°C (270°–275°F)	8 Minutes
Steam	Gravity Displacement (Wrapped)	132°–135°C (270°–275°F)	22 Minutes

Implants

2.4 mm Locking Screws, self-tapping, with T8 StarDrive recess, 4 ea.

Stainless steel	Titanium*	Length (mm)
212.806	412.806	6
212.808	412.808	8
212.810	412.810	10
212.812	412.812	12
212.814	412.814	14
212.816	412.816	16
212.818	412.818	18
212.820	412.820	20
212.822	412.822	22
212.824	412.824	24
212.826	412.826	26
212.828	412.828	28
212.830	412.830	30

2.4 mm Cortex Screws, self-tapping, with T8 StarDrive recess, 3 ea.

Stainless steel	Titanium*	Length (mm)
201.756	401.756	6
201.758	401.758	8
201.760	401.760	10
201.762	401.762	12
201.764	401.764	14
201.766	401.766	16
201.768	401.768	18
201.770	401.770	20
201.772	401.772	22
201.774	401.774	24
201.776	401.776	26
201.778	401.778	28
201.780	401.780	30

Material:

316 L stainless steel

* Titanium alloy (Ti-6Al-7Nb)

2.4 mm LCP Distal Radius Plate Instrument and Implant Sets continued

Stainless Steel (105.515) and Titanium (145.515)

Implants continued

2.7 mm Cortex Screws, self-tapping, with T8 StarDrive recess, 3 ea.

Stainless steel	Titanium*	Length (mm)
202.870	402.870	10
202.872	402.872	12
202.874	402.874	14
202.876	402.876	16
202.878	402.878	18
202.880	402.880	20
202.882	402.882	22
202.884	402.884	24
202.886	402.886	26
202.888	402.888	28
202.890	402.890	30

LCP Distal Radius Plates, volar, extra-articular

Stainless steel	Titanium**	
242.458	442.458TM	right, 5 holes head, 3 holes shaft, 47 mm
242.459	442.459TM	right, 5 holes head, 5 holes shaft, 65 mm
242.461	442.461TM	left, 5 holes head, 3 holes shaft, 47 mm
242.462	442.462TM	left, 5 holes head, 5 holes shaft, 65 mm
242.464	442.464TM	right, 4 holes head, 3 holes shaft, 47 mm
242.465	442.465TM	right, 4 holes head, 5 holes shaft, 65 mm
242.467	442.467TM	left, 4 holes head, 3 holes shaft, 47 mm
242.468	442.468TM	left, 4 holes head, 5 holes shaft, 65 mm

Material:

316 L stainless steel

* Titanium alloy (Ti-6Al-7Nb)

** Titanium alloy (Ti-15Mo)

LCP Distal Radius Plates, volar (juxta-articular)

Stainless steel	Titanium**	
242.491	442.491	left, 5 holes head, 3 holes shaft, 43 mm
242.492	442.492	left, 5 holes head, 5 holes shaft, 61 mm
242.493	442.493	right, 5 holes head, 3 holes shaft, 43 mm
242.494	442.494	right, 5 holes head, 5 holes shaft, 61 mm

2.4 mm LCP Distal Radius T-Plates, 3 holes head

Stainless steel	Titanium**	
242.477	442.477	3 holes shaft
242.478	442.478	4 holes shaft

2.4 mm LCP Distal Radius Plates, straight

Stainless steel	Titanium**	
242.479	442.479	5 holes, 48 mm
242.490	442.490	6 holes, 57 mm

2.4 mm LCP Distal Radius L-Plates, 2 holes head

Stainless steel	Titanium**	
242.500	442.500	-90°, 3 holes shaft, 40 mm
242.501	442.501	-90°, 4 holes shaft, 49 mm
242.502	442.502	+90°, 3 holes shaft, 40 mm
242.503	442.503	+90°, 4 holes shaft, 49 mm

2.4 mm LCP Distal Radius L-Plates, 3 holes head

Stainless steel	Titanium**	
242.504	442.504	+90°, 3 holes shaft, 40 mm
242.505	442.505	+90°, 4 holes shaft, 49 mm
242.506	442.506	-90°, 3 holes shaft, 40 mm
242.507	442.507	-90°, 4 holes shaft, 49 mm
242.508	442.508	+20°, 3 holes shaft, 43 mm
242.509	442.509	+20°, 4 holes shaft, 52 mm
242.511	442.511	-20°, 3 holes shaft, 43 mm
242.512	442.512	-20°, 4 holes shaft, 52 mm

Material:

316 L stainless steel

** Commercially pure (CP) titanium

2.4 mm LCP Distal Radius Plate Instrument and Implant Sets continued

Stainless Steel (105.515) and Titanium (145.515)

Implants continued

Kirschner Wires

Stainless steel	Titanium†	
292.12	492.12	1.25 mm Kirschner Wire, 150 mm, trocar point, 1 pkg. of 10
292.16	492.16	1.6 mm Kirschner Wire, 150 mm, trocar point, 1 pkg. of 10

Also Available

Additional implant modules and screw racks may also be ordered separately.

306.455	Implant Module, for LCP Distal Radius Plate Set
306.456	Lid, for Implant Module for LCP Distal Radius Plate Set
306.451	Lid, for LCP Distal Radius Plate Set Graphic Case (for 306.450)
304.206	Implant Module, for Titanium LCP Distal Radius Plate Set
304.206.11	Lid for Implant Module for Titanium LCP Distal Radius Plate Set
690.384.11	Lid, for Titanium LCP Distal Radius Plate Set Graphic Case (for 690.384)
306.461	Screw Rack, for LCP Distal Radius Plate Set Graphic Case
690.484	Screw Rack, for Titanium LCP Distal Radius Plate Set Graphic Case
690.484.11	Lid for Screw Rack (306.461) and (690.484)



306.455



306.461

Material:

316 L stainless steel

† Titanium alloy (Ti-6Al-4V)

References

1. D. L. Fernandez, J. B. Jupiter, *Fractures of the distal radius. A practical approach to management*, Springer Verlag, New York, 1996: 317–337.
2. R. A. Berger, A. T. Bishop, "A fiber-splitting capsulotomy technique for dorsal exposure of the wrist," *Techniques in Hand and Upper Extremity Surgery*, 1996; 1: 1–9.
3. D. Rikli and P. Regazzoni, "Fractures of the distal end of the radius treated by internal fixation and early function," *Journal of Bone and Joint Surgery*, 1996, 78B, 588–592.
4. D. Ring, J. B. Jupiter, J. Brennwald, U. Buchler, H. Hastings 2nd, "Prospective multicenter trial of plate for dorsal fixation of distal radius fractures," *Journal of Hand Surgery*, [Am] 1997 Sept, 22(5): 777–84.
5. F. Fitoussi, W. Y. Ip, S. P. Chow, "Treatment of displaced intra-articular fractures of the distal end of the radius with plates," *Journal of Bone and Joint Surgery*, [Am] 1997 Sept, 79(9): 1303–12.
6. M. Jakob, D. A. Rikli, P. Regazzoni, "Fractures of the distal radius treated by internal fixation and early function. A prospective study of 73 consecutive patients," *Journal of Bone and Joint Surgery*, [Br] 2000 Apr; 82(3): 340–4.
7. D. L. Fernandez, "Distal Radius and Wrist," *AO principles of fracture management*, ed. T. P. Ruedi, W. M. Murphy, New York, Thieme, 2000.
8. R. Peine, D. A. Rikli, R. Hoffman, G. Duda, P. Regazzoni, "Comparison of three different plating techniques for the dorsum of the distal radius: a biomechanical study," *Journal of Hand Surgery*, [Am] 2000 Jan; 25 (1): 29–33.
9. T. E. J. Hems, H. Davidson, A. C. Nicol, D. Mansbridge, "Open reduction and plate fixation of unstable fractures of the distal radius: a biomechanical analysis and clinical experience," *Journal of Bone and Joint Surgery*, 2000, 82(B): 83.
10. D. Rikli and P. Regazzoni, "The double plating technique for distal radius fractures," *Techniques in Hand and Upper Extremity Surgery*, 2000, 4(2), 107–114.
11. D. S. Ruch, T. A. Ginn, "Open Reduction and Internal Fixation of the Distal Radius," *Operative Techniques in Orthopedics*, 2003 April; 13(2): 138–143.
12. D. Ring, K. Prommersberger, J. B. Jupiter, "Combined Dorsal and Volar Plate Fixation of Complex Fractures of the Distal Part of the Radius," *Journal of Bone and Joint Surgery*, 2004, 86(A): 1646–52.
13. N.G. Harness, J. B. Jupiter, J. L. Orbay, K. B. Raskin, D. L. Fernandez, "Loss of Fixation of the Volar Lunate Facet Fragment in Fractures of the Distal Part of the Radius," *Journal of Bone and Joint Surgery*, 2004, 86(A): 1900–08.
14. D. W. Smith and M. H. Henry, "The 45° Pronated Oblique View for Volar Fixed-Angle Plating of Distal Radius Fractures," *Journal of Hand Surgery*, 2004, 29(A): 703–706
15. J. B. Jupiter, D. Ring, *AO Manual of Fracture Management—Hand and Wrist*, Thieme, New York, 2005.



Synthes (USA)
1302 Wrights Lane East
West Chester, PA 19380
Telephone: (610) 719-5000
To order: (800) 523-0322
Fax: (610) 251-9056

Synthes (Canada) Ltd.
2566 Meadowpine Boulevard
Mississauga, Ontario L5N 6P9
Telephone: (905) 567-0440
To order: (800) 668-1119
Fax: (905) 567-3185

www.synthes.com